

Pump installation and warranty guide for all pumps

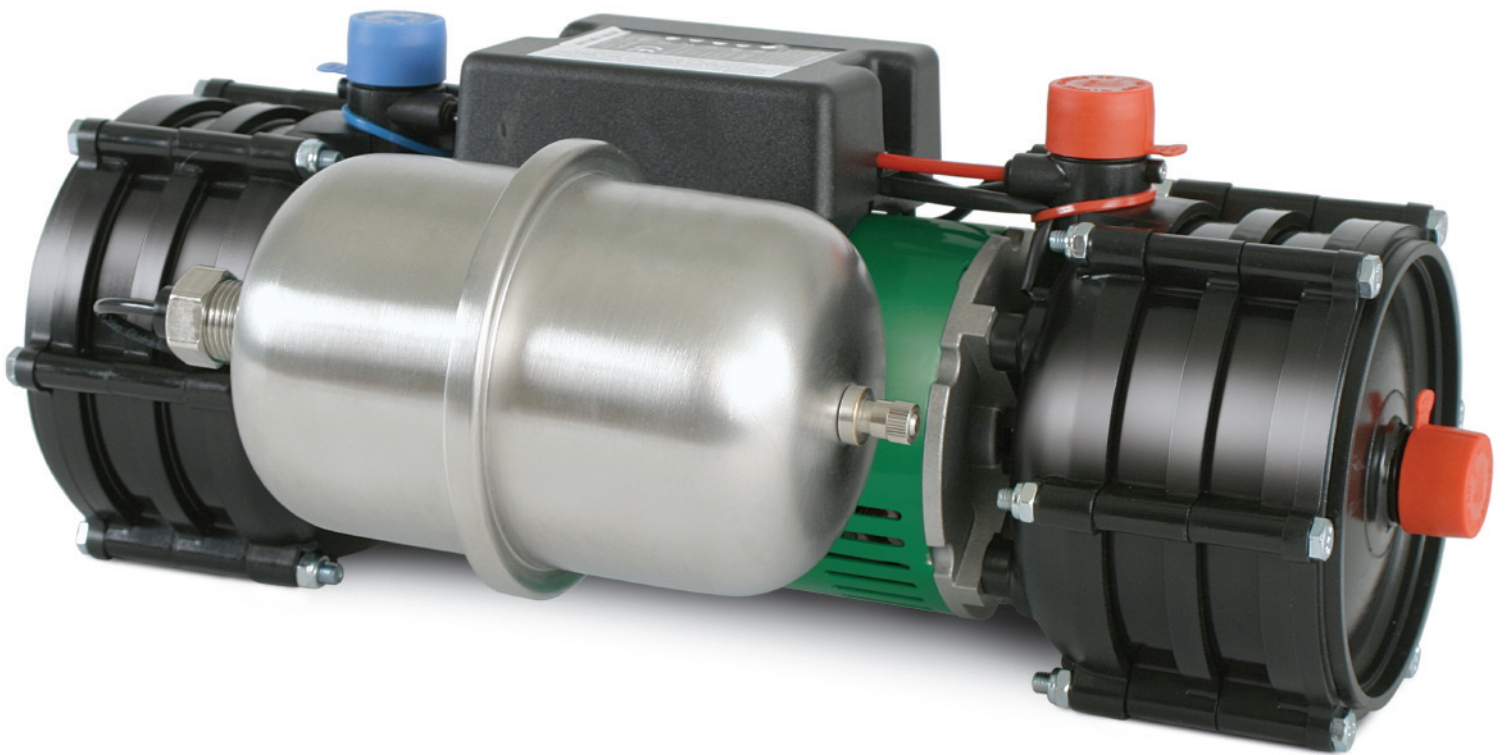

making life easier for plumbers

Pump installation and warranty guide

Important – read this first!

Correct installation is the guarantee of safety and a trouble free system. It is therefore important to read these instructions thoroughly and ensure you comply with them. Incorrect fitting can invalidate the warranty.

Pages 9 to 11 of this manual provides clarification of some of the more unusual installation requirements. If your installation is complicated or you have any questions please CONSULT THE PUMPWISE HELPLINE IMMEDIATELY. If you are calling from site and need urgent technical guidance, say so – and we will prioritise a return call.

We encourage installers to consult the Salamander helpline, where our engineers can give you first-rate advice regarding installation. Consulting the helpline will entitle your customer to an additional year's warranty FREE – all you have to do is register and implement the engineer's recommendations for your installation situation.

When the job is finished – tear off the final page of this instruction manual and hand it to the householder. This page explains the warranty provisions and provides a pre-paid warranty card. Don't forget that if you have called our helpline you should also complete the comments section of the card to say how you rate the service you received.

Thank you for choosing Salamander Pumps.

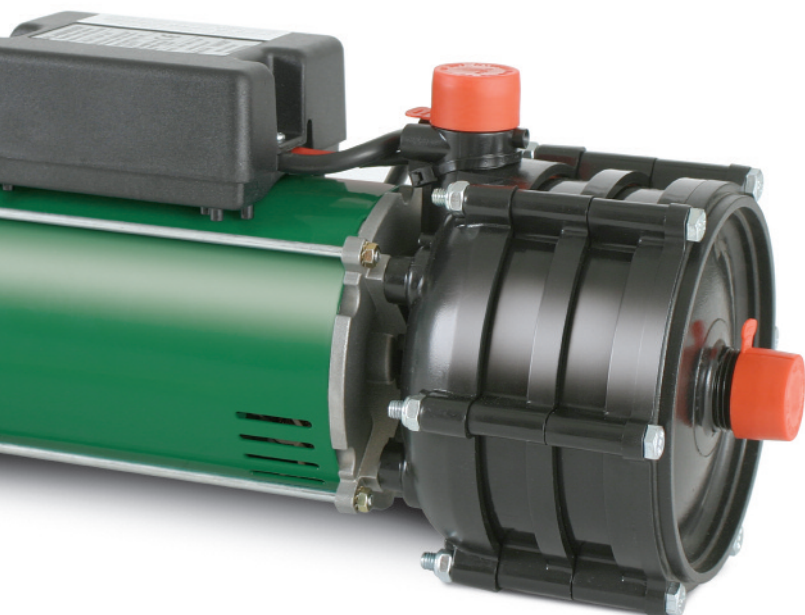

Contents

CT 50/50+/55/55+/75/75+/85/85+ pumps	1
Check you have got it right	
Notes for all RightPumps and ESP pumps	2
Check you have got it right	
RightPumps	3
Typical installations	
ESP CPV pumps	4
System operation and L.E.D. indication	
ESP CPV pumps	6
Typical installations	
All Salamander pumps	8
Plumbing, electrical and commissioning	
Helpful PumpWise guidelines	9
Cold water supplies • Storage	
Helpful PumpWise guidelines	10
Water starvation protection Pipework arrangements	
Helpful PumpWise guidelines	11
Pipework arrangements • Negative head systems Stored hot water	
General Specification	12
Your Warranty	inside back cover
Householder notes and warranty options	

CT 50/50+/55/55+/75/75+/85/85+ pumps

PLEASE FOLLOW THESE INSTALLATION INSTRUCTIONS CAREFULLY. FAILURE TO INSTALL YOUR PUMP IN ACCORDANCE WITH THESE INSTRUCTIONS WILL INVALIDATE YOUR WARRANTY.

- NEVER FIT THE PUMP DIRECTLY TO THE COLD MAINS
- THE STORED HOT WATER TEMPERATURE MUST NOT EXCEED 60°-65°C. (SEE COLUMN 2 PAGE 11).
- ENSURE THAT THE HOT SUPPLY TO THE PUMP IS VIA A SALAMANDER APPROVED METHOD (SEE POINT 8) ON THIS PAGE.
- JOINTING COMPOUNDS, BOSS WHITE, HEMP AND STEEL WOOL, MUST NOT BE USED. SOLDER FLUXES MUST NOT COME INTO CONTACT WITH THE PUMP OR AV HOSES.
- THE AV HOSES MUST NOT BE TWISTED OR BENT.
- NEVER FIT TO AN ANDREWS TYPE WATER HEATER.

It is essential to make sure that:

- 1 The cold stored water capacity is adequate for ALL THE HOUSEHOLD REQUIREMENTS. (Minimum 50 gallons per bathroom, 80 gallons for one (1) bathroom plus an en suite shower room).
- 2 The cold supplies to the cylinder and to the pump are taken from the opposite side of the cold tank to the cold mains inlet. The bottom of the cold tank MUST ALSO be checked and cleared of debris.
- 3 In systems where there are two (2) or more bathrooms, the cold supply to the cylinder MUST BE in 28mm pipework.
- 4 Multiple CWS Tanks MUST BE linked in 28mm with the bottoms of the tanks at the same level.
- 5 NEVER put a non return valve; inverted loop; restrictive balofix or an air vent on the supply pipework to a pump.

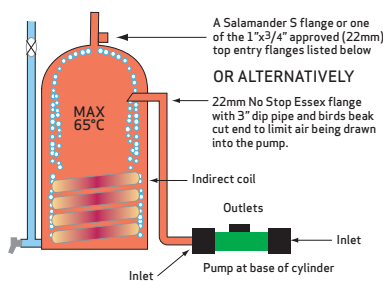

► **FIGURE 1**

- 6 The best possible position for the pump is at or near the base of the cylinder at least 600mm below the bottom of the cold water storage tank.
- 7 The area around the pump MUST BE sufficient to allow air flow for cooling of the motor.
- 8 **The best hot connection from the cylinder is either:**
 - A 3/4" NO STOP ESSEX FLANGE (see Figure 1) or
 - Alternatively a Salamander S flange or other approved top entry flanges (see column 3 page 10).
 - Never fit to top entry flange if the pump is fitted above the cylinder.
- 9 The hot supply pipework to the pump is maximum 5 metres in 22mm (HOT AND COLD SUPPLIES NOT MORE THAN 2 metres in 15mm).
- 10 With pumps that do not have isolating valves, good plumbing practice is to fit full bore isolating valves into the pipework to the pump.

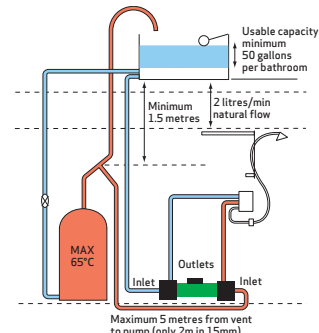

► **FIGURE 2**

Exclusive hot and cold supplies to the pump with the hot from the vent angled at 45°.

11 Acceptable exceptions are – hot supply – from the vent-angled at 45°, vertically down WITH THE hot connection at the vent, at least 1.5 METRE below the base of the CWS tank. See Figure 2.

Alternatively the hot and cold supplies to the pump can be teed off other 22/28mm supplies provided that the:

- Tee off to the pump is first call. See Figure 3.
- The cold supply to the pump is not shared with the cold feed to the cylinder.

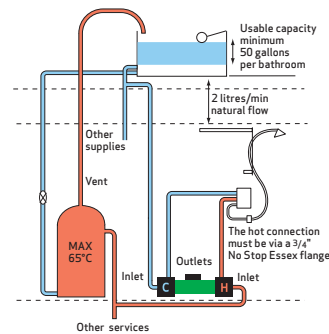

► **FIGURE 3**

12 CT50, CT50+, CT75, CT75+, are shower specific.

13 Inlets are horizontal, outlets are vertical.

PUMPS POSITIONED (above the hot outlet) See Figure 4.

An anti gravity loop (AGL) of a NO STOP ESSEX flange MUST BE fitted to all systems where the pump is mounted above the hot outlet from the cylinder. (See column 2 page 10 – anti gravity loop). In these systems the stored hot water temperature must not exceed 60°C.

All up and over pipe work must be vented at the highest point on the outlet of the pump, and a NRV fitted to the hot outlet only. LOFT MOUNTED PUMPS MUST BE PROTECTED AGAINST FROST DAMAGE.

14 Fit full bore lever valves or gate valves to inlets and outlets pipework.

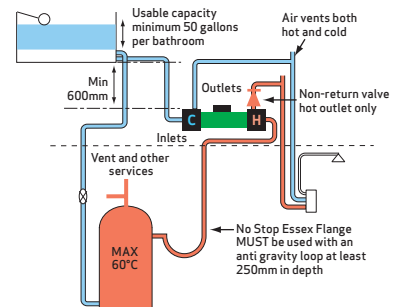

► **FIGURE 4**

In positive head systems, allow for increased resistance of long pipe runs with multiple bends. The natural flow from the shower head or other outlets MUST be at least 1ltr in 30 sec per side and 2ltr in 1 minute mixed.

Notes for all RSP, RHP, RGP and ESP pumps

Check you have got it right

PLEASE FOLLOW THESE INSTALLATION INSTRUCTIONS CAREFULLY. FAILURE TO INSTALL YOUR PUMP IN ACCORDANCE WITH THESE INSTRUCTIONS WILL INVALIDATE YOUR WARRANTY.

- NEVER FIT THE PUMP DIRECTLY TO THE COLD MAINS
- THE STORED HOT WATER TEMPERATURE MUST NOT EXCEED 60°-65°C. (SEE COLUMN 2 PAGE 11).
- ENSURE THAT THE HOT SUPPLY TO THE PUMP IS VIA A SALAMANDER APPROVED METHOD (SEE POINT 8) ON THIS PAGE.
- JOINTING COMPOUNDS, BOSS WHITE, HEMP AND STEEL WOOL, MUST NOT BE USED. SOLDER FLUXES MUST NOT COME INTO CONTACT WITH THE PUMP OR AV HOSES.
- THE AV HOSES MUST NOT BE TWISTED OR BENT.
- NEVER FIT TO AN ANDREWS TYPE WATER HEATER.

It is essential to make sure that:

- 1 The cold stored water capacity is adequate for ALL THE HOUSEHOLD REQUIREMENTS. (Minimum 50 gallons per bathroom, 80 gallons for one (1) bathroom plus an en suite shower room).
- 2 The cold supplies to the cylinder and to the pump are taken from the opposite side of the cold tank to the cold mains inlet. The bottom of the cold tank MUST ALSO be checked and cleared of debris.
- 3 In systems where there are two (2) or more bathrooms, the cold supply to the cylinder MUST BE in 28mm pipework.
- 4 Multiple CWS Tanks MUST BE linked in 28mm with the bottoms of the tanks at the same level.
- 5 NEVER put a non return valve; inverted loop; restrictive balofix or an air vent on the supply pipework to a pump.

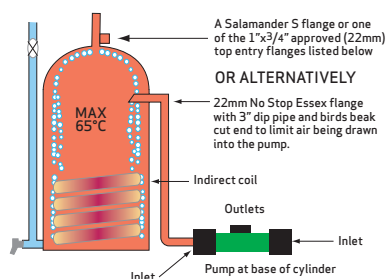
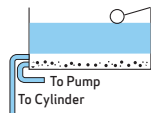

► FIGURE 5

- 6 The best possible position for the pump is at or near the base of the cylinder at least 600mm below the bottom of the cold water storage tank.
- 7 The area around the pump MUST BE sufficient to allow air flow for cooling of the motor.
- 8 **The best hot connection from the cylinder is either**
 - A 3/4" NO STOP ESSEX FLANGE (see Figure 5) or
 - Alternatively a Salamander S flange or other approved top entry flanges (see column 3 page 10).
 - Never fit to top entry flange if the pump is fitted above the cylinder.

- 9 The HOT and COLD water services to the pump MUST BE exclusive to it in 22mm pipework (NOT SHARED WITH OTHER SERVICES). For RSP 50 Maximum 2 metres of 15mm inlet pipework.
- 10 Hot supply pipework to the pump is a maximum 4 metres in 22 from cylinder.
- 11 RSP pumps are shower specific.
- 12 Inlets on side, outlets on top.
- 13 Non return valve to be fitted to all hot outlets.

PUMPS POSITIONED (above the hot outlet, hot water cylinder or in a loft position)

All up and over pipe work must be vented at the highest point on the outlet of the pump. And a NRV fitted to the hot outlet only (not ESP pumps). Loft mounted pumps must be protected against frost damage. For guidance consult PumpWise helpline 0845 129 5010.

An anti gravity loop (AGL) off a NO STOP ESSEX flange MUST BE fitted to all systems where the pump is mounted above the hot outlet from the cylinder. (See column 2 page 10 – anti gravity loop). In these systems the stored hot water temperature must not exceed 60°C.

IMPORTANT NOTICE

Under no circumstances can you fit to communal risers (eg. block of flats) or secondary circuits that are pumped. Contact the PUMPWISE helpline for clarification.

Never use an ESP twin pump to boost the supplies to an instantaneous electric shower or to a water heater.

When an ESP CPV pump is to be used to replace a conventional negative head Right/Diamond pump, then the RCM and CCM CONTROLS fitted above the old pump MUST BE REMOVED FROM THE SYSTEM.

AV couplers

With the sealing washers correctly positioned – AV coupler nuts need only be hand-tight.

For ESP CPV pumps only

NON-RETURN VALVES MUST NOT be fitted in the discharge pipework between the pump outlets and system outlets.

Never fit to an Andrews type water heater.

Right shower pumps (RSP)

Designed purely for showers. The right shower pump is best determined by the customer's expectations and choice of shower head.

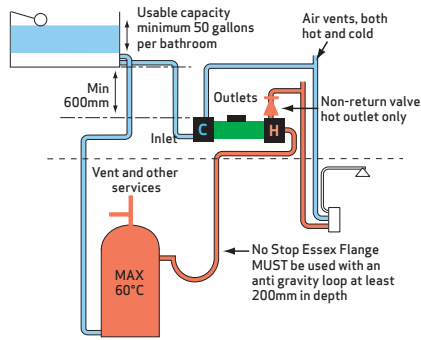

▲ FIGURE 6

Right pump fitted in loft above cylinder outlet.

In positive head systems, allow for increased resistance of long pipe runs with multiple bends. The natural flow from the shower head or other outlets MUST be at least 1 litre/min per side (hot or cold).

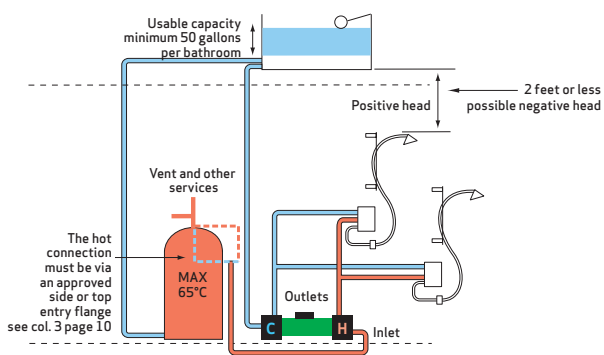

▲ FIGURE 7

Right pump feeding two showers.

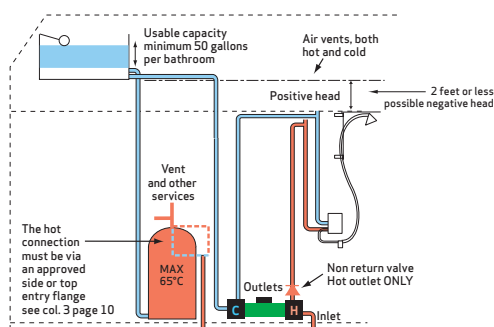

▲ FIGURE 8

Up and over pipe work from any RSP twin pump.

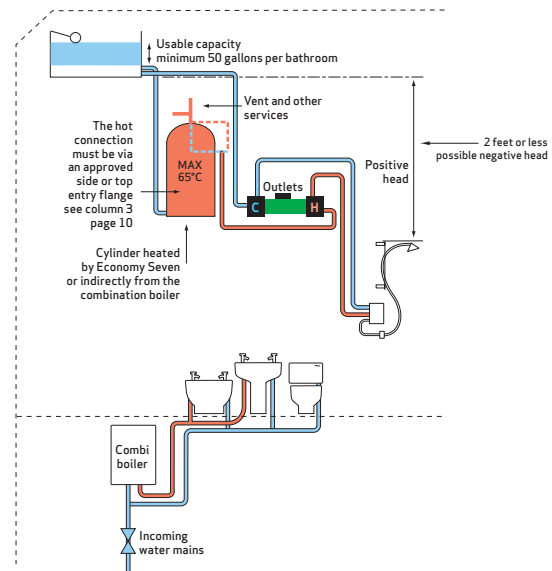

▲ FIGURE 9

Combi boiler system with RSP twin pump to boost the shower from a CWS tank and a direct cylinder.

Right whole house pumps (RHP)

Uniquely equipped with a bypass loop. Selection of the Right whole house pump for a system will be determined by the resistance of, or the pressure required at the outlets.

In these systems

- Toilets MUST BE fitted with an equilibrium ball valve.

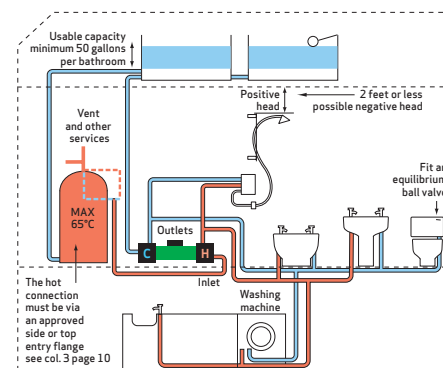

▲ FIGURE 10

Whole house system with any RHP twin pump.

ESP CPV pumps

System operation and L.E.D. indication

With electronic system protection ESP CPV pumps are the culmination of four years intensive research to develop advanced pumps incorporating micro electronic technology and sensors capable of:

- Positive or negative head operation self selection
- Supply water temperature sensing
- Dry run protection
- Sensing chronic aeration or water starvation
- L.E.D. indication of system function and any unforeseen system malfunction
- Diagnostic memory

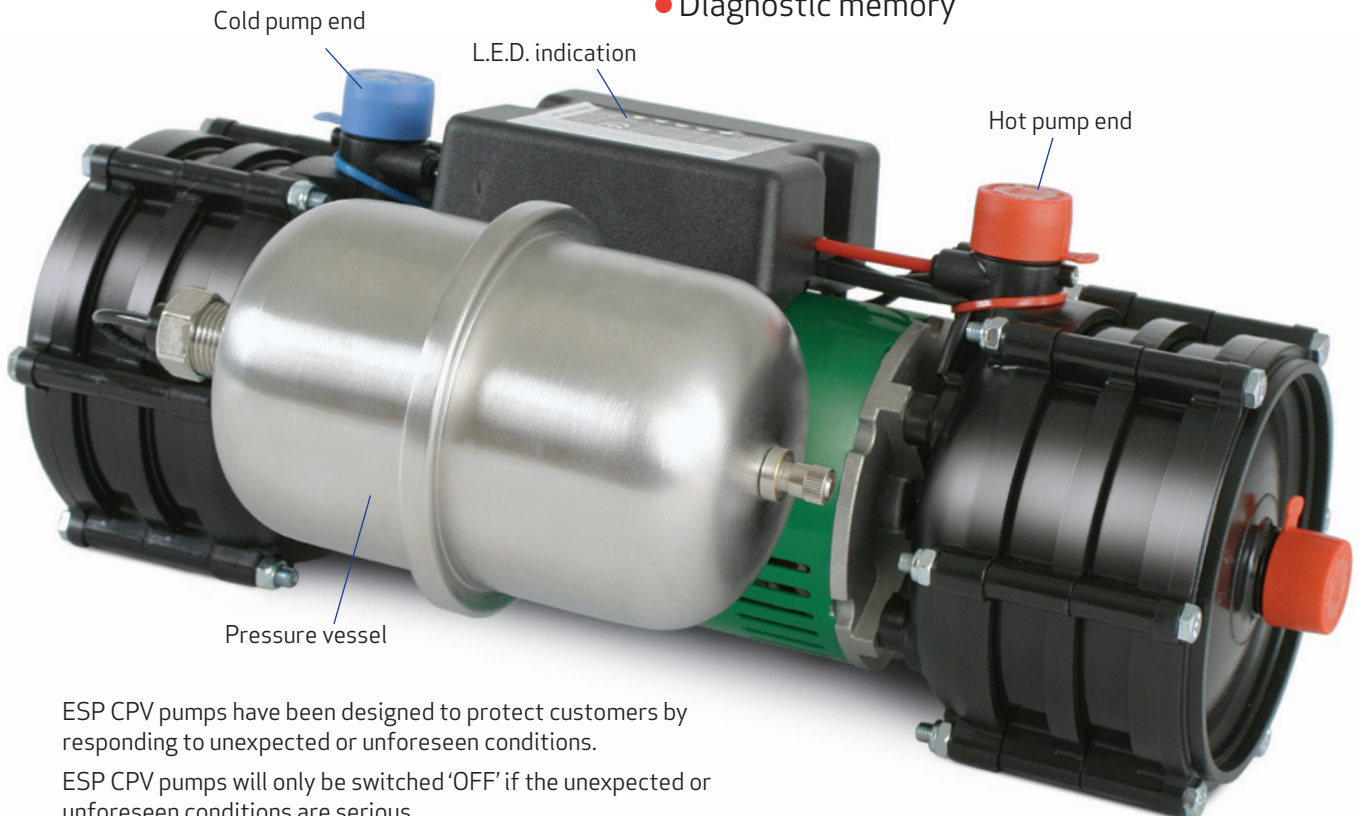

ESP CPV pumps have been designed to protect customers by responding to unexpected or unforeseen conditions.

ESP CPV pumps will only be switched 'OFF' if the unexpected or unforeseen conditions are serious.

System operation and system malfunction is indicated via five L.E.D.'s located on top of the pump junction box lid as follows:

Negative head operation

- Green L.E.D. ON

Positive head operation

- Yellow L.E.D. ON

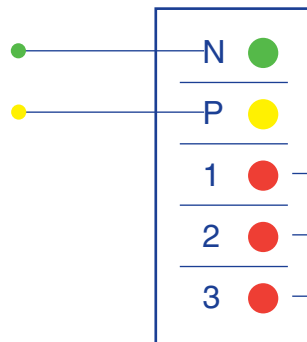

• ANY RED L.E.D. 'ON' INDICATES PUMP OFF indicating unforeseen system malfunction. Only after two (2) hours of persistent ON OFF ON OFF hunting due to a dripping (tap or shower) outlet.

• DRY RUN PROTECTION only occurs in instances of chronic aeration or water starvation after (2) ON OFF ON OFF operation and a 60 second recovery period.

• PUMP-TEMPORARILY OFF due to the hot water temperature exceeding acceptable limits. The pump will automatically reset to operate when the water temperature returns to normal.

For ESP CPV pumps only
NON-RETURN VALVES MUST NOT be fitted in the discharge pipework between the pump outlets and system outlets.

IMPORTANT NOTES

The HOT and COLD pump ends are identified by RED (hot) and BLUE (cold) tie wraps and sleeves at each outlet. See above illustration.

Patent number GB 2402444

ESP CPV pumps (negative head)

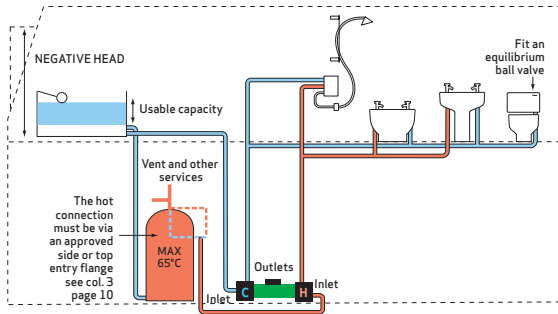

▲ FIGURE 11

An ESP CPV twin to a bathroom in a loft-conversion.

ESP CPV pumps (positive head)

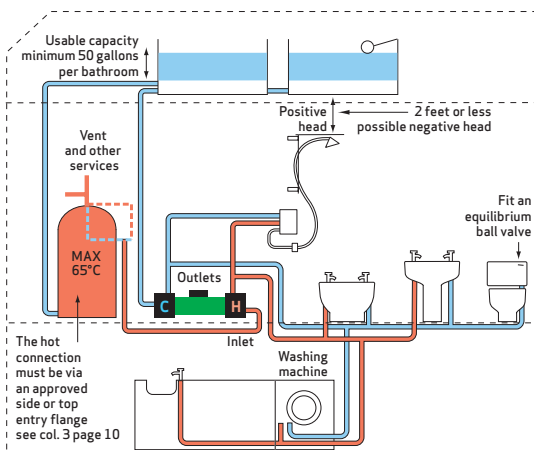

▲ FIGURE 12

ESP twin pump to a whole house system. In these systems TOILETS must be fitted with equilibrium ball valve(s).

ESP CPV SB (super booster pack)

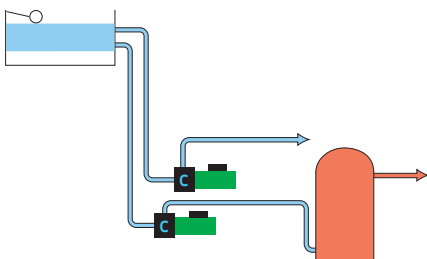

▲ FIGURE 13

Use the ESP 120 SB for un-vented mains pressure systems and pumped cold water around the house, these two options must be from cold water storage tanks.

Negative head systems

Negative head systems are those where the shower head or other outlets are above or are level with the cold water storage tank, or when the low head pressure does not provide enough natural flow to the outlet. Salamander positive head pumps require a natural flow of only 1 litre per minute per flow switch. Negative head systems are typically loft conversions or flats with showers which have self-contained hot and cold water services. See column 1 page 7.

Fully automatic negative head systems are best accommodated by using a Right ESP CPV pump (the fully integrated option which has a built-in pressure vessel and electronic system protection).

The requirements of large systems including multiple body sprays and or boosted supplies to two or more bathrooms are best served with Right ESP CPV super booster with integrated pressure vessels (see column 2 page 7).

ESP CPV

The ESP CPV range of pumps are featured on pages 5, 6 and 7. In these systems the pumps automatically determine the requirement for positive or negative head operation as the pump is commissioned. *The correct procedure for commissioning is therefore extremely important (see column 2 page 8).*

ESP CPV pumps

Typical installations

ESP CPV pumps to shower columns or steam shower cabinets

These will be required to operate **NEGATIVE HEAD** where pipework runs above tank.

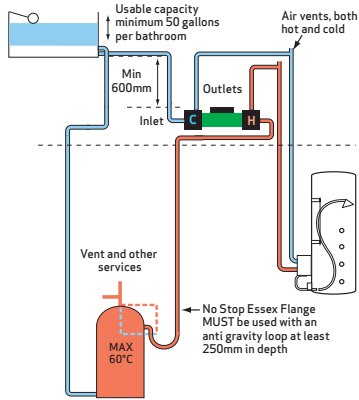

▲ **FIGURE 14**

ESP CPV pump to a shower column.

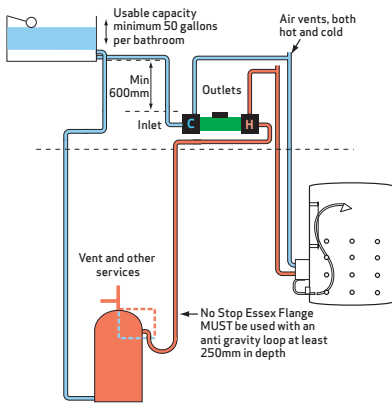

▲ **FIGURE 15**

ESP CPV pump to a shower cabinet.

SHOWER COLUMNS and STEAM SHOWER CABINETS in larger whole house systems or systems with multiple bathrooms will be best served by an ESP CPV SUPER BOOSTER (see column 2 page 7). Figs 23, 24, 25.

ESP CPV single (negative head)

These systems are best accommodated by using a Right ESP CPV single pump (the fully integrated option) which is complete with a pressure vessel and electronic system protection.

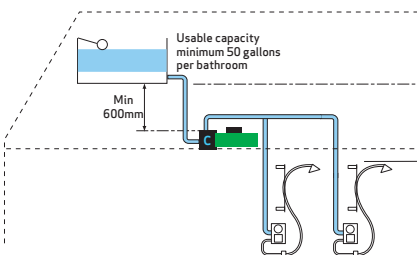

▲ **FIGURE 16**

Right ESP CPV single pump to boost tank fed supplies to instantaneous electric showers and water heaters.

ESP CPV single (negative head)

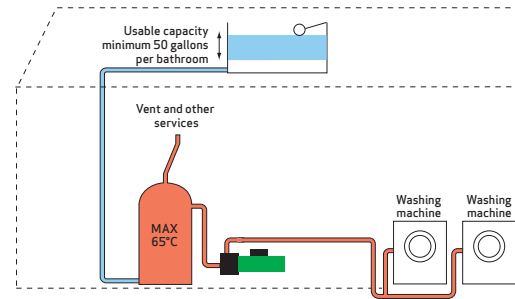

▲ **FIGURE 17**

Right ESP CPV pump to boost tank fed hot supplies to commercial washing machines or other tank fed hot or cold services.

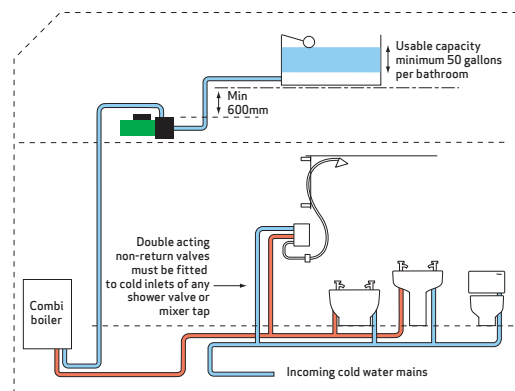

▲ **FIGURE 18**

Tank fed, pressurised cylinder or Combi boiler system with Right ESP CPV single pump to boost the hot supply water pressure and cold water mains supplies "cold" to shower: bath: basin: toilet.

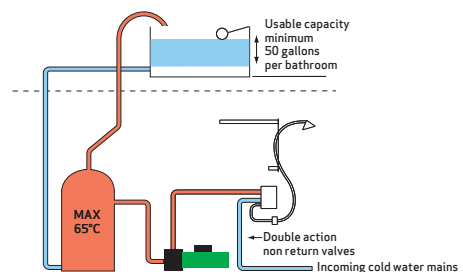

▲ **FIGURE 19**

Tank fed (hot) with cw mains cold systems **MUST USE** Right ESP CPV.

Never use an ESP single pump after the shower valve or before an open outlet.

ESP CPV twins (negative head)

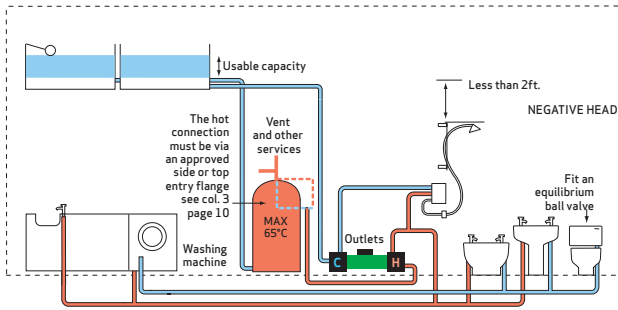

▲ **FIGURE 20**
Whole flat system with ESP CPV twin pump, such systems are likely to operate positive head when a shower is not fitted. When a shower is incorporated the system becomes negative head.

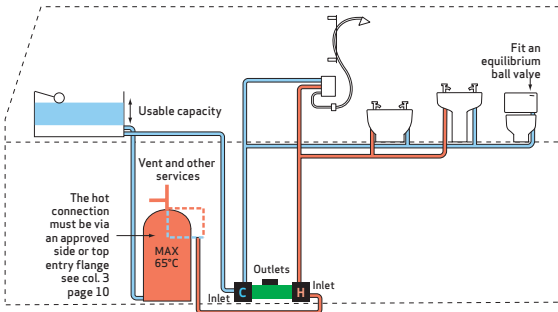

▲ **FIGURE 21**
An ESP CPV twin to a bathroom in a loft conversion.

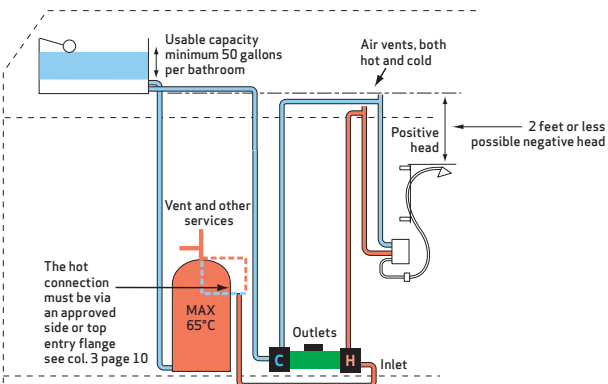

▲ **FIGURE 22**
An ESP CPV pump to a shower.

ESP CPV super boosters

Created to meet the requirements of those who live in large houses or whose idea of a really good shower is a total deluge. **In these systems toilets MUST BE fitted with equilibrium ball valves.**

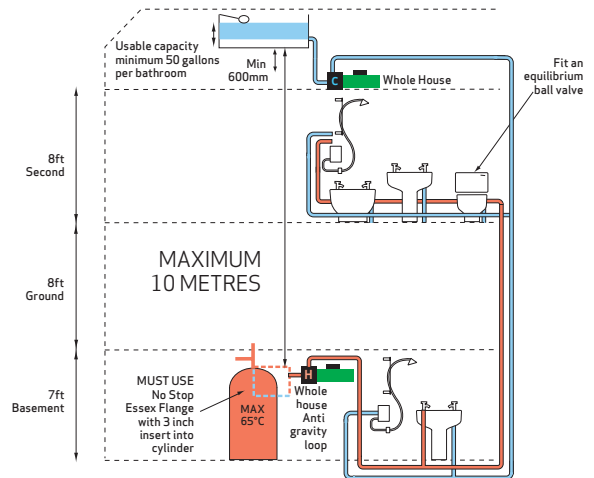

▲ **FIGURE 23**
Large whole house system with the hot and cold pumps independently mounted.

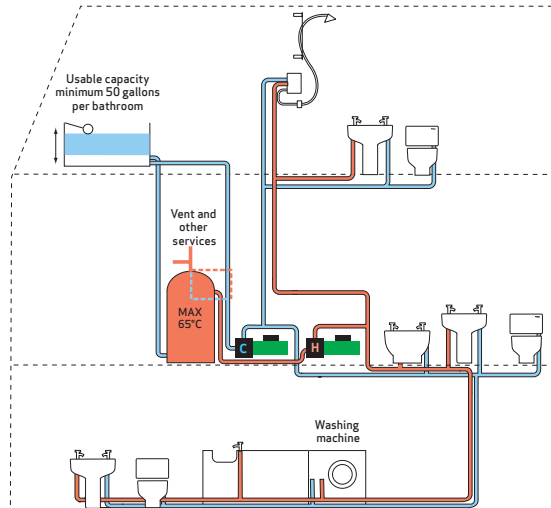

▲ **FIGURE 24**
Large whole house system with the ESP CPV SB hot and cold pumps mounted in the airing cupboard.

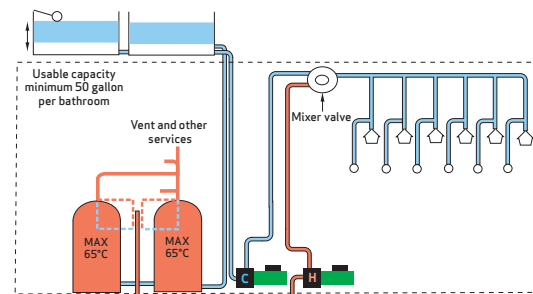

▲ **FIGURE 25**
Sports Complex with multiple showers.

All Salamander pumps

Plumbing, electrical and commissioning

Plumbing

The installation must comply with the relevant requirements or local bye-laws.

The pump MUST be mounted upright (shaft horizontal – not screwed down). Pump must be adequately vented, protected from frost, with access provided for servicing.

Jointing compounds, Boss White, Hemp and Steel Wool, MUST NOT BE USED. SOLDER FLUXES MUST NOT COME INTO CONTACT WITH THE PUMP OR AV HOSES (THIS WILL INVALIDATE YOUR WARRANTY).

All associated pipework MUST be thoroughly flushed before making final connections to the pump. Fill the pump with water before connecting to the discharge pipework.

The in-line strainers must be fitted to the hot and cold inlet supplies to the pump.

MAXIMUM STATIC HEAD – 10 METRES.

In ALL pump systems it is essential to ensure that the hot and cold stored water capacity is sufficient to meet the household requirements. (See useful notes – Usable cold water storage, page 9, Figure 28.)

Anti-vibration couplers (do not bend)

These Anti-vibration couplers are designed to limit the transfer of motor and pump vibration to the associated pipework. All Salamander Anti-vibration couplers are $\frac{3}{4}$ " BSP x 22mm push fit with built-in isolating valves except:

- The Anti-vibration couplers supplied with CT 50/75 DO NOT HAVE built-in isolating valves
- CT 50, 55, 75 and 85 are supplied with 15mm hoses with isolating valves on the inlets. CT 50+, 55+, 75+, 85+, RSP 50 and RGP 40 are supplied with 15mm hoses with isolating valves on the inlets and outlets. All remaining pumps are supplied with 22mm hoses with isolating valves on the inlets and outlets.

The Anti-vibration hoses WHICH MUST NOT be TWISTED or BENT (INVALIDATES WARRANTY) are supplied – one each angled and straight with each single pump, two each angled and straight with each twin pump.

Angled inlets straight on outlets.

- Anti-vibration coupler nuts need only be finger tight plus one quarter turn. Mechanical tools must not be used to tighten coupler nuts as this may cause damage which will **INVALIDATE YOUR WARRANTY.**

Electrical

The pump must be connected to the electrical supply using the mains cable with the attached plug. This plug must be connected to an accessible socket that has been installed in compliance with BS7671 (I.E.E. Wiring regulations).

The plug must be accessible at all times.

The pump must not be installed in a bathroom unless it is installed in a space, accessible only with the use of a tool.

If the supply cord is damaged, it must be replaced by the manufacturer, its service agent or similarly qualified person in order to avoid a hazard.

Higher rated fuses MUST NOT be used.

Cooling and ventilation

The pump should be placed in a position where there is an adequate air flow to cool the motor and separated from any other appliances that generate heat. It should be installed in a clear space allowing 100mm additional space at each side, end and top of the pump.

Before you finish

Commissioning

- First flush inlet pipework and carefully fill pump with water by discharging water from the outlet flexible coupler into a container.
- Fit pump inlet filters.
- Connect discharge pipework.
- **Check that all the pump isolating valves are open.**
- Fill system. Check for leaks.
- DO NOT RUN PUMP DRY – to do so will cause irreparable damage to your pump and will **INVALIDATE YOUR WARRANTY.**
- Open shower mixer valve/system outlets to maximum hot and cold to check the natural flow (unpumped) flow of at least 1 litre per minute – positive head systems.
- FOR RIGHT ESP CPV pumps see notes below Figure 26.
- Switch on electrical supply and then run pump for 5-6 seconds ON, 5-6 seconds OFF in turn at maximum hot and then maximum cold.
- Repeat 2-3 times.

It is **CRITICAL** to discharge water through the pump into a container before connecting the pump to outlet pipework in order to ensure the air has been discharged from inlet pipework and pump chambers. This will not happen if the outlet pipework is connected to the pump.

The best method is:-

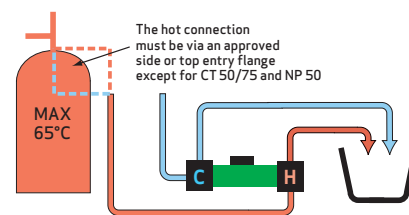

▲ FIGURE 26

How to toggle pump into negative head configuration

If the orange L.E.D. (P) light is on turn off power. Turn power on and the pump will run. Then the pump will stop and the orange L.E.D. (P) will go out and the green L.E.D. (N) will come on. When the green L.E.D. (N) comes on turn off power, then back on within 5 seconds. The pump will run for the second time and stop on the orange L.E.D. (P) which will then go out and the green L.E.D. (N) will flash off, on – then the green L.E.D. (N) will stay on.



Recovery of cold storage

The recovery rate of a typical 1/2 inch high pressure part II BS1212 ball valve is:

15PSI (1bar)	0.97 galls/min
30PSI (2bar)	1.34 galls/min
40PSI (2.7bar)	1.58 galls/min
60PSI (4bar)	1.94 galls/min

Aeration of pump and cylinder from CWS tank

This occurs when the incoming cold mains ball valve is positioned above the cold feeds to the cylinder and to the pump – aerated water is drawn into the pump as illustrated.

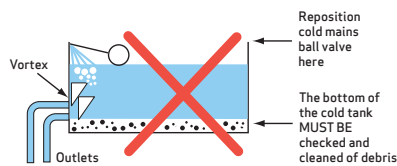

▲ FIGURE 27

Chronic aeration of the pump occurs when this problem is combined with inadequate storage capacity and/or when the volume of water drawn by the pump and other services exceeds the refill rate and creates a vortex which draws air and possibly debris into the pump.

Cold storage usable capacity

The usable capacity of cold storage is easily calculated as the capacity of water in the cold tank above the cold feeds to the cylinder, the pump and other outlets – see formula.

Formula for calculation on rectangular tank:

$$\text{Depth (15") x width (23") x length (36") = 12,420 cu inches}$$

$$\text{Volume cu inches (12,420) x 0.01639 = 203.56 litres}$$

$$\text{Volume litres (203.56) x 0.22 = 44.78 gallons.}$$

Formula for calculation on circular tank:

$$\text{Depth (15") x radius (17") x radius (17") x 3.142 (Pi)}$$

$$= 13,621 cu inches$$

$$\text{Volume cu inches (13,621) x 0.01639 = 223 litres}$$

$$\text{Volume litres (223) x 0.22 = 49 gallons.}$$

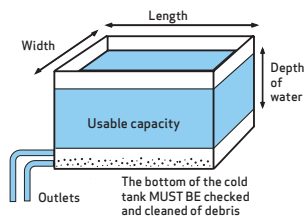

▲ FIGURE 28

Pre-plumbed direct or indirect combination units

These are purpose-made units typically for use in multiple flat developments, usually in towns and cities where it is advantageous and desirable to provide the occupants with completely independent hot and cold water services.

In these systems the ideal pump is an ESP 50/75 CPV. For alternative types of combination units see Elson, below and Fortic (type) Figure 31 page 10.

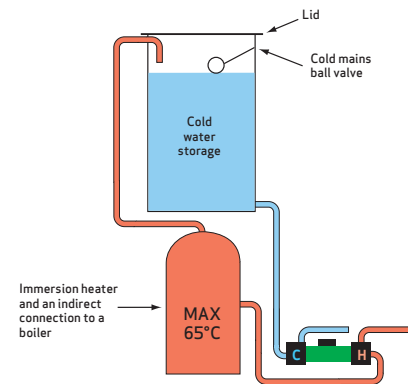

▲ FIGURE 29

Elson (type) tanks

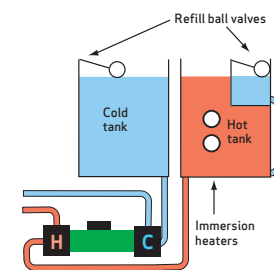

▲ FIGURE 30

- In these systems it is important to ensure the hot and cold water storage capacity is adequate for the type of pump to be used.
- The refill ball valve on the small cold tank which refills the hot tank is correctly set to prevent aeration of the hot supply water to the pump. Smaller capacity Elson Tank systems may benefit from a WSP – water starvation protection unit (see column 1 page 10). For guidance consult the Salamander PumpWise helpline 0845 129 5010.



A Salamander initiative to:

- ✓ Select the right pump
- ✓ Eliminate the risk of an incorrect installation
- ✓ Pump warranty extended to 3 years
- ✓ A quiet life and peace of mind

Helpful PumpWise guidelines

Water starvation protection • Pipework arrangements

Fortic (type) tanks and pre-assembled units

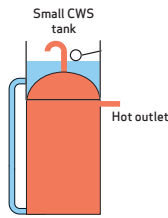

▲ FIGURE 31

Typically used in very small flats and houses. Not usually with sufficient water capacity of cold water for pumped systems.

Water starvation protection

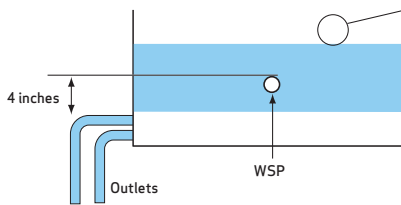

▲ FIGURE 32

In systems where it is absolutely not possible to increase the usable cold water storage capacity to meet the increased demand of a pumped system; a WSP (water starvation protection unit) may be considered. The WSP is a Salamander level switch which must be positioned 4" higher than the highest outlet from the cold water storage tank. When the water level drops too far the WSP will switch off the pump until the CWS water level is recovered.

- **Never fit to an Andrews type water heater.**
- **Contact the helpline for clarification.**

Anti-gravity loops

An anti-gravity loop (AGL) must always be fitted to systems where the pump is positioned above the hot outlet from the cylinder. The AGL which limits aeration of the hot supply to the pump is formed by bending the pipework downwards for 250mm, as it exits the Essex Flange, before rising again to the pump.

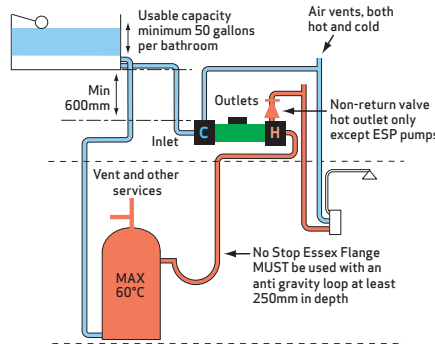

▲ FIGURE 33

Combi boilers and water heaters

As these appliances are invariably supplied directly from the cold mains – they are not normally suitable for booster pumps. The exceptions are featured in Figures 9 and 18 on pages 3 and 6.

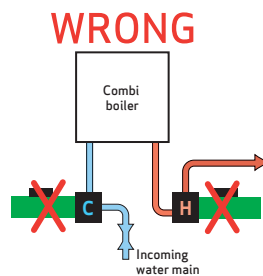

▲ FIGURE 34

Horizontal cylinders

As horizontal (torpedo) cylinders are problematic for boosted systems consult PumpWise for guidance and correct use of an approved top entry flange.

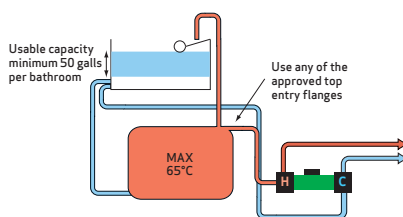

▲ FIGURE 35

Approved flanges (cylinders)

The ¾" No Stop Essex and the other approved top entry flanges with extension pipes into the cylinder represent the best known means of ensuring minimal aeration of the hot supply water to the pump. The No Stop Essex flange is in all circumstances the best option.

S flange

Complete with compression 'pump' and 'open vent' connections. Also supplied with an adaptor to connect to 1" 'male' and 'female' top entry cylinders.

York flange

These may be used in systems where the hot water requirement is less than 20 LPM.

Warix flange

- A The Vent connection MUST BE from side in Warix Flange.
- B The supply connection to the pump MUST BE FROM THE TOP of the Warix Flange via a 22mm compression elbow and thereby avoid inverted loops.
- C In systems where there are one bathroom and an en-suite shower. Or two or more bathrooms the cold feed to the cylinder MUST BE in 28mm pipework.

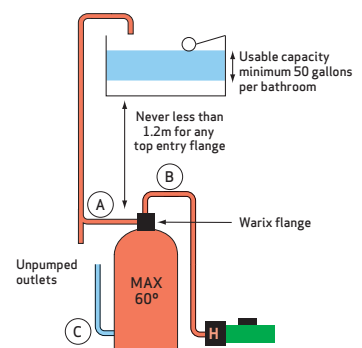

▲ FIGURE 36

General Specification

Applications

All Salamander pumps are designed to boost low pressure hot and cold supplies from tank-fed services. When supplies from a water heater or a combination boiler are to be boosted contact the Salamander PumpWise helpline 0845 129 5010 for guidance.

Voltage

220-240 volts 50 Hz.

Motor type

Capacitor start and run induction type motor with stainless steel shaft and in-built resetting thermal protection (complies with BS5000 part 11).

Pump materials

All moulded components are manufactured from Acetal Copolymer. Or close coupled glass filled polypropylene.

Maximum head

ESP 50 CPV	5 metres
CT 50/50+/55/55+/75/75+/85/85+	15 metres
All other pumps	10 metres

Pumps fitted with RCM3 maximum 3 metres static head.

Anti-vibration couplers

CT 50, 55, 75 and 85 are supplied with 15mm hoses without isolating valves. CT 50+, 55+, 75+, 85+, RSP 50 and RGP 40 are supplied with 15mm hoses with isolating valves. All remaining pumps are supplied with 22mm hoses with isolating valves.

Mechanical seals

Rotary mechanical face seals (carbon rotary element with ceramic counter face). Scale deposits in water supplies can cause the mechanical seal to stick if left for long periods without use. We recommend the pump be ran at least five minutes every four weeks to 'exercise' all working parts.

Connections

¾" BSP male.

Initiation

Fully automatic, flow switch operated, requiring 1ltr in 30 sec per side or 2ltr in 30 sec mixed. Except Right ESP CPV pumps when required to operate in negative head mode.

Temperature

Maximum fluid temperature 65°C.

Salamander PumpWise

Is your guarantee to:

- Selecting the right pump for the job.
- The avoidance of installation pitfalls.
- A THIRD YEAR WARRANTY FREE.

Salamander pumps benefit from a full 2 years warranty. This can be extended to 3 years in situations where installers consult our helpline through the Pumpwise initiative and register the pump on completion of the installation.

PumpWise helpline 0845 129 5010

A Salamander initiative to help customers and to provide a support service which is second to none. Installers and customers can be sure of a speedy and sympathetic response to requests for technical help guidance and advice.

Pump noise

With the technological advances achieved in RightPumps, Salamander has taken another step forward in the quest to supply all our customers with even quieter centrifugal pumps. Despite this no pump is completely silent. Correct installation (AV couplers straight) will minimise vibration and transmission noise. The CT range of pumps are characterised by a high pitched hum or whine.

Warranty

Salamander pumps benefit from a full 2 years warranty. This can be extended to 3 years in situations where installers consult our helpline through the Pumpwise initiative and register the pump on completion of the installation.



An extended warranty can be arranged subject to payment of a nominal annual fee. For Extended Warranty Scheme details and application form Tel: 0845 129 5010.

Incorrect installation may invalidate the pump warranty.

The company operate a policy of continuous development and reserves the right to change any of the specifications of its products without prior notice. All information data and illustrations given in this leaflet may be subject to variation.

This appliance is not intended for use by persons (including children) with reduced physical, sensory or mental capabilities, or lack of experience and knowledge, unless they have been given supervision or instruction concerning use of the appliance by a person responsible for their safety. Children should be supervised to ensure that they do not play with the appliance.

Standards and approvals

Splash proof rating IPX2.

Complies with the requirements of current British and European safety standards for household and similar electrical appliances.

Meets with Compliance with European Community Directives (CE).

Due to continuous improvement and updating specifications may be altered without prior notice.

Your Warranty

At Salamander Pumps we aim to supply an inherently strong, durable, user friendly and competitively priced product. All Salamander pumps are capable of supplying increased water pressures efficiently and reliably in any domestic situation; most importantly they are also 'plumber friendly'.

Salamander Pumps benefit from a full 2 years warranty. This can be extended to 3 years in situations where installers consult our helpline through the Pumpwise initiative and register the pump on completion of the installation.

Incorrect installation may invalidate the pump warranty. Please read the full terms and conditions overleaf.

The PumpWise initiative is the cornerstone of our support service to customers and the means by which we guarantee:

- Selection of the right pump
- Avoidance of installation pitfalls
- An extended third year warranty FREE

To obtain advice from PumpWise, call 0845 129 5010 (09.00 hrs to 17.00 hrs weekdays).

Once details have been taken by one of our operators, we will call you back at our expense.

Your showering sensation for life

In order to continue enjoying the showering sensation brought to you by your Salamander Pump:

- Please complete and return the attached Warranty card.
- Take care that the temperature of your stored water NEVER exceeds the recommended maximum of 65°C (A maximum of 60°C if the pump is positioned above the hot outlet from the cylinder).
- Contact the PumpWise helpline at any sign of aeration or spluttering of the discharge water from the shower or other outlets.

Our PumpWise commitment

We promise to help you select the right pump and eliminate the risk of incorrect installation. We strive to design and manufacture a robust quality product that will delight our customers. We assure you that should you experience a problem the PumpWise helpline is there to help; our engineers will provide immediate advice and, if necessary, arrange to fix the problem on site.

Extended Warranty

Your pump warranty can be extended for a period of 3 years from the end of the standard warranty period.

The Scheme exists to protect customers from unexpected or unforeseen pump breakdown.

Participation in the Extended Warranty Scheme is activated on completion of an extended warranty application form and payment of a nominal sum.

For more details and further technical assistance consult PumpWise.

Telephone: 0845 129 5010

Facsimile: 0845 377 9180

E-mail: tech@pumpwise.co.uk

2 | |

Freepost RSKJ-TACY-ZEGT
Salamander Pumps
Unit 2c Colima Avenue
Enterprise Park West
Sunderland
SR5 3XE

To the installer

Please follow the guidelines for installation provided in this brochure and call the PumpWise helpline for installation advice. Once installation has been completed and the system has been tested to your satisfaction, please assist the customer in completing the prepaid Warranty Card.

Terms, conditions and warranty

1 The Scope of the Warranty

SALAMANDER PUMPED SHOWER SYSTEMS LTD ("the company") Warrants subject to the terms and conditions below for the Warranty period(s) specified in paragraph 3 that the Company shall:

Repair or replace free of charge the product(s) specified on the Warranty card or any component part thereof (together referred to as "the equipment") which shall in the opinion of the Company have proved defective by reason only of the Company's materials or workmanship providing always that the Company shall be under no obligation whatsoever under this Warranty to repair or replace equipment which shall have been misused modified altered or transformed in any way without the consent in writing of the Company or if any component or accessory shall have been replaced by a type not specified by the Company or if the equipment is incorrectly installed or operated or used other than as described in the instruction manual or if any servicing or repair of the equipment shall have been carried out otherwise than by an authorised Company dealer appointed by the Company ("dealer")

The Company's liability under this Warranty is limited to the said repairs or replacement and shall under no circumstances extend to any financial loss or damage including consequential losses alleged to have been suffered by the claimant.

Subject as provided in this warranty and except were the equipment is sold to a person dealing as a consumer all warranties, conditions or other terms implied by law are excluded to the fullest extent permitted by law.

Nothing in this warranty shall exclude liability for death or personal injury caused by the Company's negligence

2 Terms and conditions

This Warranty shall only be enforceable by you if the following terms and conditions have been complied with:

- That the pump has been installed in accordance with the installation instructions, guidance and advice contained within the installation and warranty guide and/or provided by the Salamander PumpWise® help desk.
- You are the original purchaser of the equipment from a dealer and not an assignee or subsequent purchaser of the equipment.
- You must evidence the date of purchase by retaining the original invoice from the dealer. Without such evidence the Company reserves the right to reject any such claims under the terms of this Warranty.
- Within 15 days of delivery of the equipment to you the Warranty card is accurately completed and returned to the Company.
- Within thirty days of discovery of a defect giving rise to liability under paragraph 1 above you give notice thereof in writing to the Company.

3 The Warranty periods

The Warranty periods referred to in paragraph 1 above are as follows:

- Products manufactured by the Company 2 years from date of purchase provided the warranty card is completed and returned to the Company within 15 days of purchase.
- Products supplied by the Company, but not of the Company's manufacture – 1 year from date of purchase.
- The warranty period in respect of any product repaired or replaced under the warranty shall be part of the above period(s) which remain unexpired.
- In the event of a claim for repairs or replacement being made under the terms of this Warranty in the circumstances where in the opinion of the Company the defect has not been caused by the Company's materials or workmanship then the Company reserves the right to charge the claimant at its current hourly rates and list prices in respect of any service engineer's time and any replacement of parts.
- This Warranty is given in addition to and does not affect your statutory rights as a consumer.
- This Warranty is valid and enforceable for equipment purchased and used exclusively in the UK and The Republic of Ireland only.
- Where the Company makes a replacement the equipment replaced shall be returned to the Company forthwith and shall become the property of the Company.
- No authority has been given to any person, firm or company to vary the terms of this Warranty.

Salamander Pumps

Salamander Pumped Shower Systems Limited

Unit 2c Colima Avenue, Enterprise Park West, Sunderland SR5 3XE

Telephone: 0845 129 5010

Facsimile: 0845 377 9180

E-mail: tech@salamanderpumps.co.uk



Warranty card

Please supply the following information:

Pump serial number	Model	Date of purchase ____/____/____
--------------------	-------	---------------------------------

1 User name

Address _____

Postcode _____ Tel No. _____

2 Installer name

Address _____

Postcode _____ Tel No. _____

3 Supplier from whom system was purchased

Name _____

Address _____

Postcode _____

4 What does your pump boost? Shower Multiple showers

Whole house Other (please specify) _____

5 Where is the pump installed? Loft Airing cupboard

Under bath Other (please specify) _____

6 What is the approximate distance in feet from the pump to the cylinder?

Horizontal _____ Vertical _____

7 What is the approximate cold water storage capacity in gallons?

25 40 50 70 100

8 How is the hot water heated?

Gas Oil Solid fuel Aga Electric

9 Does the DHWS cylinder have independent controls for:

Zone YES NO Temperature YES NO

What is the cylinder-stat setting? _____

10 Who chose the pump? Householder Plumber

Merchant Showroom Builder

11 Why did you choose a Salamander pump?

Comments _____

I am interested in an extended warranty. Please tick box
Please send details of the Extended Warranty Scheme and application form.